



## OPERATING INSTRUCTIONS DES-7



MRM **PROCOTM** Pvt Ltd

**Works:**

E 41/5, Okhla Industrial Area, Phase II New Delhi -110020

Ph: 011-30883538-41, 9810344265, 9310883837, Fax: 0-1130883536

Email:mrmprocom@gmail.com

**Corporate office:**

238, Sukhdev Vihar, New Delhi -110025

Ph: 26913223



## *Index*

- 1.0 Introduction**
- 2.0 Protection, Supervision Salient features**
- 3.0 Measurement & Display**
- 4.0 Annunciations**
- 5.0 Contacts**
- 6.0 Timers**
- 7.0 Switches Description**
- 8.0 Annunciations Description**
- 9.0 Lamp Test**
- 10.0 Operating Mode**
  - 10.1 Auto Mode**
  - 10.2 Manual Mode**
  - 10.3 Off Mode**
  - 10.4 Test Mode**
  - 10.5 Remote Mode**
- 11.0 Programming mode**
  - 11.1 Parameter Mode**
  - 11.2 Annunciation Mode**
  - 11.3 Programming Solenoid Mode**
- 12.0 Faults**
  - 12.1 Internal Faults**
  - 12.2 External Faults**
  - 12.3 Fault Reset**
- 13.0 Communication**
- 14.0 Model Selection**
- 15.0 Terminal description**
- 16.0 Specifications**
- 17.0 Connection Diagram**

## 1.0 Introduction

- 16 Bit RISC, state of art, microcontroller based System.
- True RMS measurement of all measured parameters with 1% accuracy of measured value (Not full scale) Fully operational up to 4V. Can withstand a voltage dip up to 0V for 1sec.
- 14 annunciation
- All system parameters are user programmable
- Suitable for all types of engines
- All digital inputs are optically isolated for enhanced reliability
- All outputs are through potential free contacts for system stability and reliability
- All contacts are protected by TVS to strengthen the EMI/EMC capabilities of the unit.
- Housed in 92X92mm Din Standard housing.

## 2.0 Protection, Supervision Salient features

- Three Phase Generators voltage monitoring and protection for under/over voltage and over speeding. Three Phase Generators current monitoring and protection over Current/load.
- DC Battery Voltage supervision (Under & Over voltage)
- 5 digital input for system protection

## 3.0 Measurement & Display

DES-7 equipped with 16X2 LCD display and displays

- Generator 3 Phase voltage(Ph-N)
- Generator 3 Phase Current
- Generator Frequency
- Battery Voltage
- Generator Run Hour
- RPM
- Programmed settings

Normally the display auto scrolls and displays a set of parameter for 10 seconds, but any time the Next key (↑) can be pressed to select the next parameter window.

## 4.0 Annunciations

DES-7 is equipped with the following annunciations for system status and faults

- Measured Parameters
- LLOP (Fault)
- HWT(Fault)
- Fuel (Fault)
- DG frequency(Fault)
- DG Voltage (Fault)
- DG Over Speed (Fault)
- DG Over Current(Fault)

## 5.0 Contacts

The following potential contacts are provided. Annunciation contacts are available in models requested with Annunciation features.

- Crank (NO)
- Fuel (NO)
- Hooter (NO)
- Charger (NO).

## 6.0 Timers

DES-7 is equipped with the following timers:

- Generator voltage supervision timer (variable)
- Generator over current supervision timer (variable)
- Generator over speed supervision timer (Variable)
- Stop Solenoid on time (variable)
- Fuel supervision time (variable)
- LLOP supervision time (variable)
- HWT supervision time (variable)
- Auxiliary Supply Under/Over voltage supervision & warning timer (Fixed)
- Hooter Reset Time(Fixed)

## 7.0 Switches Description

DES-7 has 4 switches provided on its front panel. Switch can have more than one functions assigned to them. The table below describes the operation of these.

S.No.	Switch Symbol	Switch Function	Description
1	↑	Next	<b>Normal operation mode:</b> In this mode, it is used to change the parameters being displayed on LCD. <b>Programming Mode:</b> Next key is used to select the next parameter to be programmed.
2	+ Start	Increment	<b>Programming Mode:</b> It is used to increment the value of the parameters under programming. <b>Normal operation mode:</b> It is used to Start the Engine
3	- Stop	Decrement	<b>Programming Mode:</b> It is used to decrement the value of the parameter under programming. <b>Normal operation mode:</b> It is used to Stop the Engine
4	R	Reset	Reset key resets the Hooter and Fault signals. The first press shall reset the hooter and next shall reset the faults. A long press of 1 Sec shall reset both.
5	R & -	Programming Mode Entry	Press “R” Key and then press “-” while the “R” Key is pressed to enter the programming mode.

## 8.0 Annunciations Description

DES-7 has 8 annunciations on its front panel. These announce the faults .

S. No.	Nomenclature	Description
1.	Gen. Vol	This LED blinks when the engine is stopped on voltage fault
2.	O/Load	This LED blinks when the engine is stopped on over load fault
3.	O/Speed	This LED blinks when the engine is stopped on over speed fault
4.	Chg. Alt	This LED is On if the Dynamo signal is received.
5.	Emer	This LED blinks when the engine is stopped on Emergency
6.	LLOP	This LED blinks when the engine is stopped on LLOP Fault
7.	HWT	This LED blinks when the engine is stopped on High Engine Temperature
8.	Fuel	This LED blinks when the engine is stopped on Low Fuel

**9.0 Operation.**

DES-7 is an engine monitoring and supervisor unit.

The engine can be Started/Stopped from the front panel of DES-7 or externally by means of key Switch etc. DES-7 automatically detects that the engine on conditions by monitoring the generator voltage and starts monitoring the engine for under/over voltage, LLOP, HWT and emergency faults along with over load(over current ) conditions. On detection of any of these faults for the pre-programmed duration the engine is automatically shut down.

The run hour time of engine is recorded in internal non-volatile memory.

**10.0 Programming mode**

DES-7 has provision to program the operating parameters and annunciations separately.

Programming Mode can be entered any time by simultaneously pressing R &  $\bar{\phantom{R}}$  switches While in program mode, the 4<sup>th</sup> digit (left most) shall have a digit indicating the parameter under programming. The following table details the various programmable parameters:

Parameter Mode

Sl. No	Parameter	Explanation of parameter	Factory setting	Setting Range
1	Generator O/V	Max. permissible voltage, above this the voltage is treated unhealthy & the Generator is stopped.	270V	80-300V
2	Generator U/V	Min. permissible voltage, below this the voltage is treated unhealthy & the Generator is stopped .	180V	80-300V
3	Gen Sup Delay	The time for which the Generator voltage should, continuously be unhealthy to generate a fault condition.	10Sec	0-999 Sec.
4	Generator O/C	Maximum allowed current through generator. Current above this is treated as over current and generator is stopped if this condition persists for a pre programmed time in 5	40Amps	1-120 Amps
5	Gen O/C Delay	Time for which over current is allowed	5Sec	0-999Sec
6	Generator O/S	Maximum allowed speed of the generator. Speed above this is treated as fault and generator is stopped if this condition persists for a pre programmed time in 7	65.0	
7	Gen O/S Delay	Time for which over speed is allowed	5	
8	Fuel<< Delay	Time delay before this fault can be activated.	5 Sec	0-999Sec
9	LLOP Delay	Time delay before this fault can be activated.	5 Sec	0-999Sec
10	HWT Delay	Time delay before this fault can be activated.	5 Sec	0-999Sec
11	Hooter Reset Tim	The time for which Hooter will be kept active after a fault, if not reset externally	30Sec	0-100Sec
12	Stop Sol On Time	The time for which stop solenoid will be kept active while stopping the engine	30Sec	0-100Sec

13	Gen Pick Up Vol	Generator voltage above which the generator is presumed to have started and working	100V	80-150V
----	-----------------	---	------	---------

### 10.1 Programming Solenoid Mode

For changing the solenoid mode first press (R) (reset) button, than press + button while the reset button is pressed. The fourth digit shall display “ H”. There are two possible modes.

**Mode 0** In this mode fuel solenoid contact changes from Open to Close at the time of cranking and remains close till the genset is running. For stopping the generator this contact opens.

**Mode 1** In this mode fuel solenoid contact remains open at the time of cranking and till the genset is running. For stopping the generator this contact closes for a user programmed time.

**Don't change the mode while generator is running. It's a good practice to switch OFF and than switch ON the battery supply after changing this mode.**

## 11.0 Faults

There are two categories of faults

- Internal Faults
- External faults

### 11.1 Internal Faults

Internal faults are the faults, which do not need any external signals and are detected by the system itself. They are:

- Generator Voltage Unhealthy. .
- Generator Over Speed. The
- Over Current.

### 11.2 External Faults

Those faults which cannot be sensed by the unit itself (these faults are not reflected by the generator voltage) and are to be provided externally. They are:

- LLOP
- HWT
- Fuel
- Emergency

### 11.3 Fault Reset

- **Internal Faults & LLOP fault:** All internal faults and LLOP fault can be reset by pressing (R) switch after the generator is stopped.
- **External Fault:** These faults cannot be reset till the engine is running and/or fault conditions persist. Once the faults are rectified, the fault can be reset by pressing Reset switch (R). In case the engine fails to stop “STOP KEY” can be pressed for manual attempt to stop engine

## 12.0 Terminal description

Terminal Number	Description
1	Generator R Phase Voltage
2	Generator Y Phase Voltage
3	Generator B Phase Voltage
4	Generator R Phase current through external Cts
5	Generator R Phase current through external Cts
6	Generator Y Phase current through external Cts
7	Generator B Phase current through external Cts
8	<b>Common terminal for CTs</b>
9	LLOP
10	Alt Chg
11	HWT/HCT
12	Emergency
13	Low Fuel
14	<b>Common for contacts</b>
15	Hooter Contact
16	DG Vol Available Contact
17	Sol. Contact
18	Crank Contact

## 13.0 Specifications

AC voltage withstand	330 VAC (Phase to neutral)
Measurement Accuracy	1%
Surge 1.2/50Usec	2.5KV
Battery Voltage	Suitable for 12V/24 VDC System
Min. voltage to power on	9V
Min Running Voltage after	
Power on	4V
Max. Battery Voltage	35V
DC Interruption time	1 Sec.
Contact(Hooter)	NO, 24V / 2A
Contact(Fuel)	NO, 230V / 6A
Contact(Crank)	NO, 230V / 6A
Contact(DG Vol)	NO, 24V / 2A
Cut out Dimensions	92mm X 92mm
Depth	120mm
Digital Input Level	Battery Voltage (Negative)

### 14.0 Connection Diagram

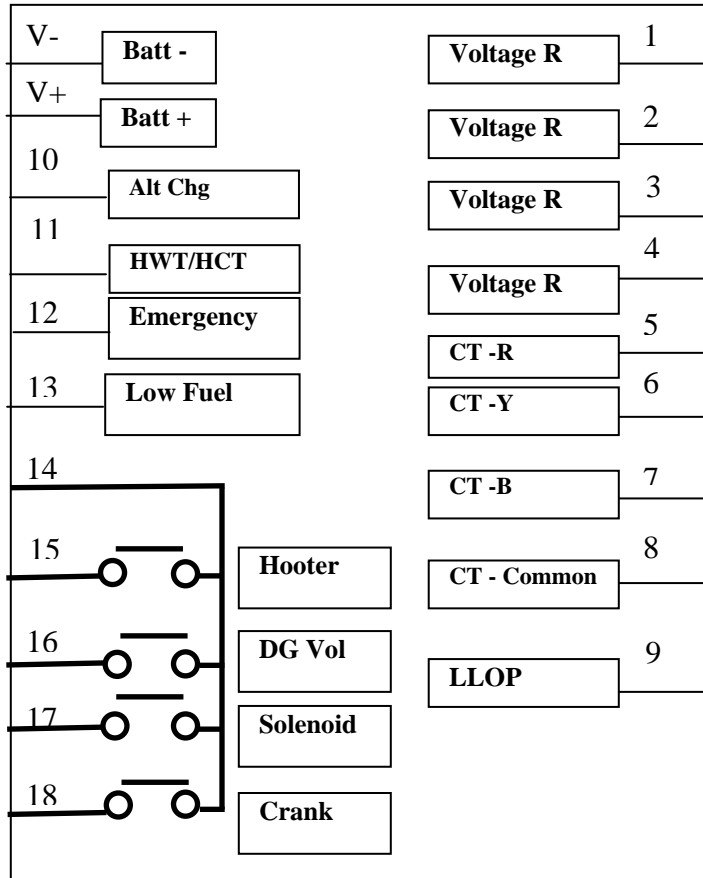

*It is our endeavour to constantly upgrade our products, hence specifications are subject to change without any notice*

